

## Flow-through chlorine electrolysis system for swimming baths

Disinfection of bathing water is an essential part of water treatment for swimming pools. With TECHNOLINE, an innovative, high-quality method for medium-sized swimming pools, disinfection can be performed by means of electrolysis.

TECHNOLINE disinfects bathing water without use or storage of any hazardous substances such as chlorine gas, chlorine bleach or chlorine tablets. All chlorine required for disinfection is produced directly on site using common NaCl salt (cooking salt, sea salt, sodium chloride) - no risks whatsoever plus one very pleasant side effect: salted water.

Salted water has a refreshing and invigorating effect and is gentle on the skin too. It is also indicative of the sort of quality of life bathers can enjoy every day with Technopool flow-through chlorine electrolysis systems. The systems operate according to the SALT-WATER-LIGHT® method, the efficiency of which has been proven time and time again in private homes, hotels, therapy and exercise pools and indoor/outdoor municipal or commercial pools around the world.

## Versatile and eco-friendly

Salty bathing pool water is essential for the flow-through chlorine electrolysis system method (also known as chlorine electrolysis systems in inline operation). Salt may be used in tablet form as granules, sea salt, rock salt or (natural) brine.

TECHNOLINE requires a salt content of 0.5 %, which corresponds to 5 g per litre or 5 kg per m<sup>3</sup> of bathing water. By comparison, sea water has an average salt content of ~3.6 %.

As well as generating the disinfectant hypochlorous acid, the system causes other chemical compounds to be decomposed in the water which reduce contamination of pool water considerably.

The system consists of a control unit and an electrolysis cell installed directly in the pool's water circuit and can be used in any swimming pool providing its components are corrosion-proof and hence designed for use with salt water. Algae, germs and bacteria will then be a thing of the past.

TECHNOLINE is activated via a time switch at regular intervals and/or via measuring and control equipment chosen by the operator (e.g. the EASYPOL SMART 02 water sampling station) according to water data (chlorine, pH or Redox), which is measured on ongoing basis in the pool water.

## Safe and reliable

Flow-through chlorine electrolysis systems are user-friendly and reliable when it comes to operation. Disinfection capacity can in addition be manually adapted to changes in pool water contamination in 5 adjustable increments between 0 and 100 %.

The systems are extremely low maintenance as TECHNOLINE incorporates a self-cleaning function for the electrolysis cell. Electrolysis cells are wearing parts with a service life of 1 to 5 years and are available in 12 g Cl/h (SC 11) and 15 g Cl/h (SC 14) versions.



Description	Order No.
TECHNOLINE SC 11 Flow-through chlorine electrolysis system for max. 12 g Cl/h, max. 80 m <sup>3</sup> pool volume inc. power supply unit, control unit, electrolysis cell with housing for assembly	91120001
TECHNOLINE SC 14 Flow-through chlorine electrolysis system for max. 15 g Cl/h, max. 100 m <sup>3</sup> pool volume inc. power supply unit, control unit, electrolysis cell with housing for assembly	91120002

## In Short

- Disinfection of bathing water without use of any hazardous substances
- System operates using salt - no use of chlorine chemicals
- Safe, economical and environmentally friendly
- Proven in practice, tried and tested many times over
- Simple installation
- Can be activated via measuring and control equipment
- Manually adjustable power
- Compact design for installation in the smallest of spaces
- Low maintenance, self-cleaning function
- No reddened eyes, no irritation of the mucosa
- Disinfection can be controlled externally and regulated on site
- For a max. pool volume of 100 m<sup>3</sup>
- For indoor and outdoor pools

## Product Information TECHNOLINE

### Technical data

TECHNOLINE	SC 11	SC 14
<b>Primary (mains voltage)</b>		
Connection	1.3 m cable with shock-proof plug	
Power supply	230 V AC	
Switch-on current	< 8 A	
Power consumption	< 90 W	
<b>Secondary (electrolysis cell)</b>		
Connection	1.0 m cable with special connector	
Power supply	0 ... 7.5 V DC, controllable	
Current	12 A	15 A
<b>Other parameters</b>		
Power display	LED	
Control unit protection class	IP 45	
Control unit weight	~3 kg	
Electrolysis cell weight	~1.3 kg	~1.4 kg
Disinfectant capacity	0 ... 12 g Cl/h	0 ... 15 g Cl/h
Pool size	< 80 m <sup>3</sup>	< 100 m <sup>3</sup>
Salt content	0,5 ... 0,6 %	
Temp. of pool water	15 ... 35 °C	
Nominal pipe diameter	DN 40 / ø50 mm	

### Accessories

Description	Order No.
TECHNOLINE SC 11 electrolysis cell with 1 m connection cable, without housing	91920001
TECHNOLINE SC 14 electrolysis cell with 1 m connection cable, without housing	91920002
Electrolysis cell housing	91920015
Cable for external release for control via measuring and control equipment	91190000
EASYPOL SMART 02 Redox water sampling station	42401008
EASYPOL SMART 02 chlorine water sampling station	42401011

### Infrastructure requirements

- For a max. pool volume of 50 or 75 m<sup>3</sup>
- Salted water, 0.4 ... 0.7 %
- Corrosion-resistant swimming pool equipment
- Water circulation piping, DN 50 PVC pipe
- 230 V AC voltage supply in engineering room
- In-line connection for circulation/filtering system
- Time switch and measuring and control equipment
- Water/salt values with very low percentage of iron and manganese

- Water values after increase of saline content less than 20° dH total hardness

### Installation diagram

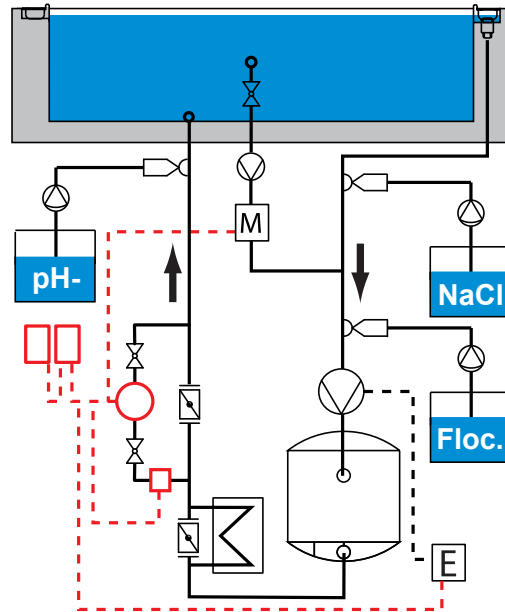

### Dimensioned drawings

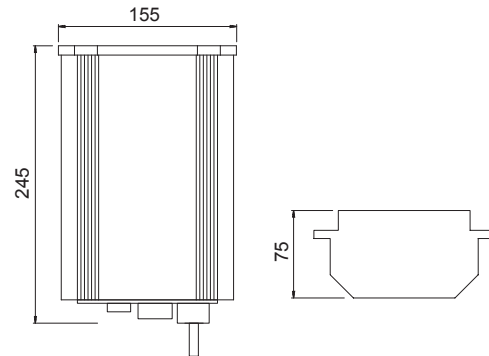

Control unit

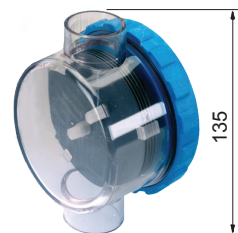

Electrolysis cell

All dimensions in mm